



# 2K Paint

Now available in a **UNIQUE Aerosol** for the paint professional

- Professional two part paint in one aerosol. **UNIQUE.**
- Innovative nozzle & valve technology in Combination with new propellant technology. **UNIQUE.**
- SprayMax has more yield, faster work speed, & broader spray pattern than conventional aerosols. **UNIQUE.**
- Professional paint results, sprays like a Spray Gun. **UNIQUE.**
- No Cleaning Spray Gun. **UNIQUE.**
- No thinner for cleaning. **UNIQUE.**
- No compressor. **UNIQUE.**
- Less over spray. **UNIQUE.**

## How the 2K Aerosol Works

Red release nozzle in outer cap to be used on pin at the bottom of can to evacuate hardener into paint from cylinder.

SprayMax valve and nozzle in combination with new propellant technology.

Up take pipe and valve.

Perforated top of cylinder to release hardener into paint from cylinder.

Two part paint.

Separate hardener in cylinder (paint mix is 4:1 ratio).

When ready to activate take red cap from outer cap, insert into the pin on the bottom of the can using limited force, activating hardener into paint.

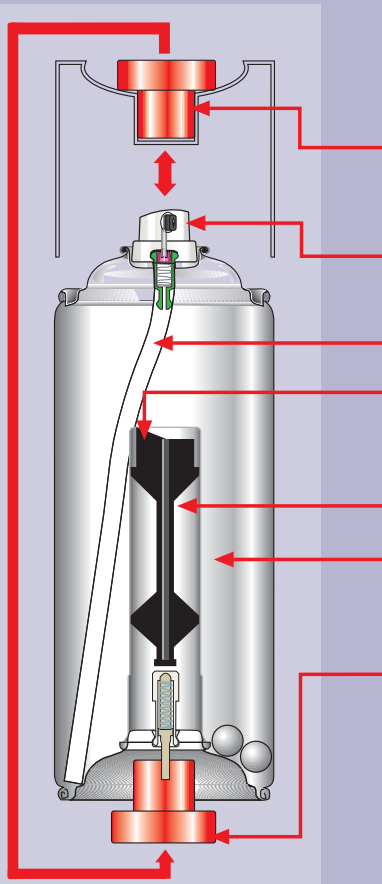

**2K**  
 Urethane Filler Primer Gray  
 Apprêt de Remplissage Uréthane  
 Imprimación/Rellenador de uretano gr

## The Unique Two Part Aerosol product range:

2K Rapid Primer Filler (Non-isocyanate)		Part # 3680031	
<b>contents</b>	12,3oz/350g	<b>color shades</b>	gray
<b>drying time</b>	1 hour (rapid drying)	<b>potlife</b>	24 hours
<b>application</b>	Two-Component Primer that Fills & has Rust Cure Properties on New & Rusty Surfaces, when you want the right protection for your Automotive, Marine & Industrial Refinish Repairs on Most Metal Surfaces as well total protection to any metallic substrate.		
<b>advantages</b>	<ul style="list-style-type: none"> <li>• Quick drying</li> <li>• Easy to sand</li> <li>• Overcoatable with any 1K/2K base/topcoat system</li> </ul>		

2K Urethane Filler Primer		Part # 3 680 030	
<b>contents</b>	13.2oz/373g	<b>color shades</b>	gray
<b>drying time</b>	12 hours	<b>potlife</b>	48 hours
<b>application</b>	Two-Component Urethane Primer & Filler, that has Rust Cure Properties on New & Rusty Metal Surfaces, a Universal Primer giving Total Protection to All Base Coat Finishes for Automotive, Marine & Industrial on All Metal Substrates.		
<b>advantages</b>	<ul style="list-style-type: none"> <li>• Excellent filling and sag resistance.</li> <li>• Easy sanding and excellent flow.</li> <li>• Wet-in-wet application possible.</li> </ul>		

2K Rapid Cut-In Spot Clearcoat		Part # 3 680 062	
<b>contents</b>	11,8oz/337g	<b>color shades</b>	transparent
<b>drying time</b>	1.5 hours	<b>potlife</b>	24 hours
	IR: 8-10 min.		
<b>application</b>	Two-Component Premium Urethane Clear Coat for Panel as well as Spot Repair Refinishing Ideal for Door Jambs, Cut in of New Parts & Bumper Repair. Offers Outstanding Gloss & Durability Finish, Excellent Flow and Leveling Properties make this Clear Extremely Easy to Apply. Drying time 1,5 hours. If using a Heat Lamp it can be Sanded or Buffed in 10 minutes.		
<b>advantages</b>	<ul style="list-style-type: none"> <li>• Quick drying</li> <li>• Very smooth flow and long-lasting high-gloss</li> <li>• Excellent chemical, weather, fuel and abrasive resistance</li> </ul>		

2K Epoxy - Rust Cure primer		Part # 3680032	
<b>contents</b>	14,1oz/401g	<b>color shades</b>	beige
<b>drying time</b>	12 hours	<b>potlife</b>	4 days
<b>application</b>	Two-Component Primer Epoxy Based, for Universal Applications & on all Critical Surfaces, Epoxy Primer Fills & has Excellent Rust Cure Properties On New & Rusty Surfaces, Slower to dry which is compensated by the Excellent Improved adhesion to all metal surfaces. The perfect Primer for all paint coats for Automotive, Marine & Industrial, for all Metal & NE-Metal Substrates.		
<b>advantages</b>	<ul style="list-style-type: none"> <li>• Excellent adhesion and corrosion</li> <li>• suitable for all surfaces</li> <li>• overcoatable with any 1K/2K base/topcoat systems, polyester putty and polyester products</li> </ul>		

2K Glamour High Gloss Clearcoat		Part # 3 680 061	
<b>contents</b>	11,8oz /335g	<b>color shades</b>	transparent
<b>drying time</b>	12 hours	<b>potlife</b>	24 hours
<b>application</b>	Two-Component Clear Coat for All Base Coats, Standard Drying Time 12 Hours, which can be Reduced, & can be Air or Force Dried for a Perfect O.E.M look U.V. Protection Package Excellent Clarity and Superior Long Term Durability on Cars & Motorcycles.		
<b>advantages</b>	<ul style="list-style-type: none"> <li>• Easy to apply</li> <li>• Very smooth flow and long-lasting high-gloss</li> <li>• Excellent chemical, weather, fuel and abrasive resistance</li> </ul>		

Distributed in North America Exclusively by:



**U.S. Chemical & Plastics**  
**A Division of Alco Industries Inc.**  
**600 Nova Drive S.E.**  
**Massillon, Ohio 44646**  
**330-830-6000**  
**www.uschem.com**

Distributed by